

Hazard Warnings

Hazard warnings in this manual indicate potential harm to the user or the product. For the person interacting with the product, the level of risk includes consequences ranging from slight, up to lethal injuries. As for the product, disobeying the warnings may cause damage to the equipment and/or void the warranty. Therefore, said warnings are made apparent to instruct and warn the user, which precautions have to be made prior to performing any actions described in this manual. The user must read and be familiar with the manual, before performing any tasks as described in this manual.

Hazard warnings in this manual are presented in these three forms:

WARNING: These warning notices refer to personal safety. Failure to obey these notices could result in personal injury or death.



WARNING

CAUTION: General precautions must be made. Failure to obey these notices could result in personal injury and/or equipment damage.



CAUTION

NOTE: Directs the user's attention to essential information.

(ex)(r)AB40 explosion drawing and spare parts list

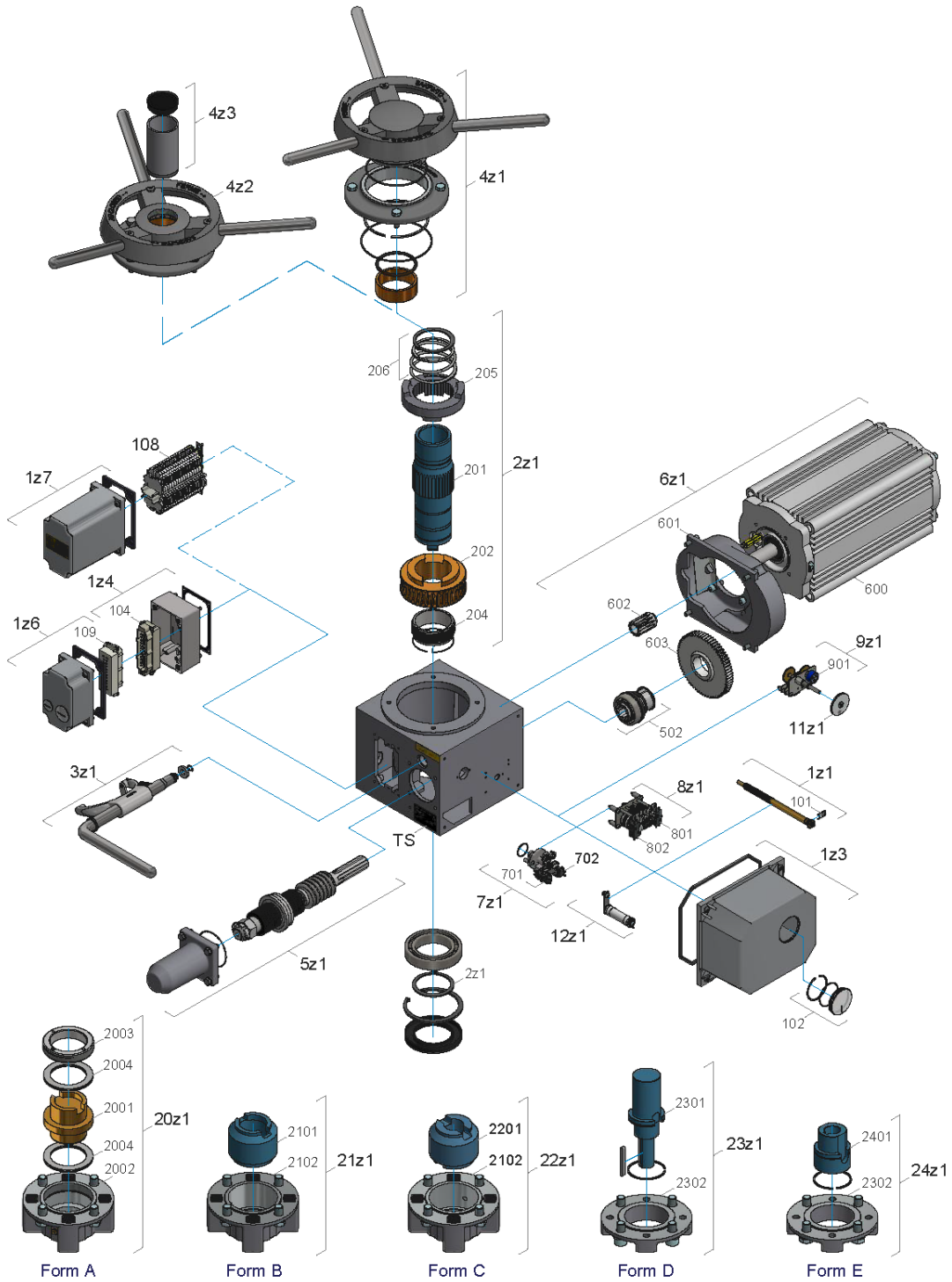

CAUTION: When ordering spare parts, you **must** provide the **serial number** (see type shield).
 Use only original spare parts supplied by SCHIEBEL. Using other parts will render the warranty void.
 Illustrations may differ from actual spare parts.



CAUTION

Asm.	No.	Description
1z1		Helical cut pinion gear with bracket
	101	Pinion gear bracket
1z3		Signalling unit cover with sight glass
	102	Sight glass
1z4		Bottom part frame plug
	104	Entire Smod plug actuator side
	108	AK36 terminal block (ex)
1z6		Connection cover (low)
	109	Entire Smod plug customer side
1z7		Connection cover (high)
2z1		Output shaft
	201	Output shaft
	202	Worm gear
	204	Helical gear
	205	Coupling ring
	206	Spring assembly
3z1		Manual lever
4z1		Handwheel
4z2		Handwheel SpA
4z3		Spindle cover
5z1		Worm shaft
	502	Hub
6z1		Entire motor
	600	Motor
	601	Motor flange
	602	Motor pinion
	603	Plastic gearwheel
7z1		Torque unit
	701	Torque switch S1, S15
	702	Torque switch S2, S16
8z1		Limit switch unit
	801	Limit switch S3, S7
	802	Limit switch S4, S8
9z1		Teletransmission gear
	901	ESM21
11z1		Mechanical position indicator
12z1		Heater
TS		Type plate

Asm.	No.	Description
20z1		Output form "A" F14 assembly
	2001	Threaded spindle nut
	2002	Flange "A"
	2003	Ring nut
	2004	Bearing assembly
21z1		Output form "B" F14 assembly
	2101	Std "B" socket
	2102	Std flange "B"
22z1		Output form "C" F14 assembly
	2201	Std "C" claw coupling
	2102	Std flange "B"
23z1		Std output form "D" F14 assembly
	2301	Output shaft D Ø30
	2302	Flange D/E/S
24z1		Std output form "E" F14 assembly
	2401	Output shaft E Ø30
	2302	Flange D/E/S